

LUMINOUS LIQUID FLAME SYSTEM

LUMINOUS ARENA FLAME

KEY FEATURES

- ▶ Dual electrode spark ignition with 100% duty cycle
- ▶ Lightweight compact enclosure with stainless-steel burn chamber
- ▶ Direct floor and truss mounting with multiple fixing points
- ▶ Controlled via single cable conveying data and power from the fuel station
- ▶ High quality UK and EU sourced components
- ▶ CE certified



DESCRIPTION

The Luminous Arena Flame is the mid-level flame from the Luminous Liquid Flame System range, typically achieving a flame jet of 8m/26ft. The Luminous Arena Flame is compatible with a Luminous Fuel Station which can be either a Luminous Pump or Luminous Accumulator. This modular solution allows the user to select any flame that best suits their application and couple it with any fuel station, or run different flames from the same fuel station.

The Luminous Arena Flame is coupled with the fuel station via a fuel hose with locking, flush faced quick release couplings that are not accidentally disconnected and don't have recesses that can be contaminated with dirt. The flame is automatically identified by a Luminous Fuel Station via RDM and provides the user with warning lights when armed and enabled. The two high power spark electrodes provide convenient and reliable fuel ignition without the need for flammable gas pilot. Luminous Arena Flames are lightweight, compact and weather resistant, and can be directly mounted on floor or truss. A non-structural cover allows owners to easily replace and renew, keeping the product looking in good condition even after many years of use.

The Luminous Pump can control up to five flames via DMX 512 or 24VDC external input such as a wireless device. For DMX control a safety enable channel and five fire channels can be programmed from the Luminous Pump. With a control expansion pack, additional Arena Flames can be connected to the Luminous Pump, up to a maximum of 20. A Key-safe, E-Stop with optional hold-to-run device is required to activate the system to maximise the safe operation.

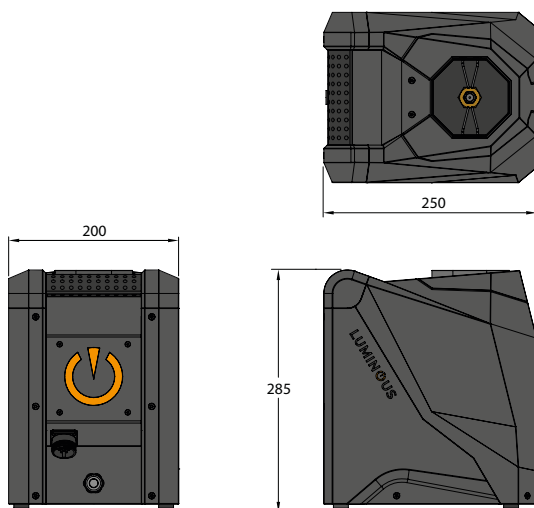

SPECIFICATION

Mass	7kg
Dimensions	230 x 230 x 330
Max pressure	20 bar / 290 p.s.i.
Flame Projection	8m
Fuel type	IPA or Isopar
Filtration	Internal 'last chance' filter' prolonging valve life
Voltage	90 - 250 VAC
Control	Digital control from fuel station via DMX or 24v input
Ignition	Duel Ignition systems 4 x spark electrodes
Safety	Tilt sensor Warning Indicator

Disclaimer: These specifications are general guidelines for your particular project. All product specifications and data are subject to change.